

DECLARATION OF PERFORMANCE

No. 010.005-CPR-2013.09.04

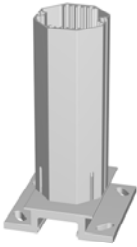

By JSK - Approved on behalf of the manufacturer by Lars Tvette, Vingrom 04.09.2013

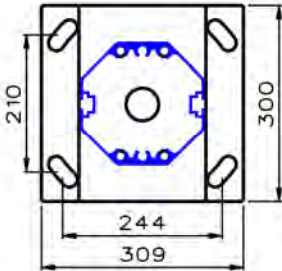
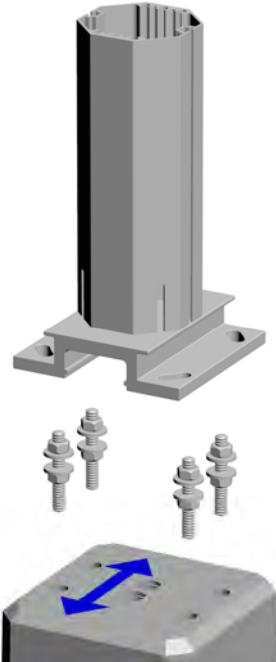
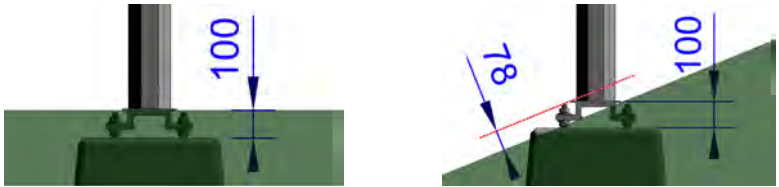

Product name :	Norsafe Mast NM190-60
Product specifications : 	The mast is delivered complete with base plate Tested and approved NS EN12767: 100, NE, 2 Approval no.: 2004/050368-045 Order no.: See next page Width : 190 mm Base plate height: 75 mm Base plate, width x length: 309 x 300 mm
Material / Surface treatment :	Mast: Aluminium 606385 T6 - 6005 T6 Base plate: 6082 T6 chromated Bolts: BUMAX 109 (A4 - acid proof stainless steel)
Data / Weight / Capacity : 	Bending Capacity: 60 kNm Stiffness bending: 1812 kN/m ² Torsional capacity: 42 kNm Stiffness torsion: 59,22 kN/m ² Min. C-C with 1,5m opening at 20° angle: 1,814 m Shape factor (force coefficient) wind: 1,1 Weight mast: 14,09 kg/m Weight base plate: 7,71 kg Bolt patterns for foundation (M20): 244 mm x 210 mm
Assembly: 	See separate descriptions for assembly of signs and foundations. <ul style="list-style-type: none"> - Before assembly; control that the top of the foundation is approx. 100mm under surrounding terrain. - Assemble the bolt set in the foundation. - Check (with, for example, a plank) that the top of the bolts are not sticking up from the hole, higher then the surrounding terrain. - Remove the top 4 washers and nuts and level correct height on the lower washers. The lower washers shall be approx. 60-70mm under terrain. - Put the mast with base plate in place and assemble the upper washers and nuts. Use appropriate lubricant/Teflon spray to avoid damage of the threads in the acid proof steel nuts. Assemble the nuts with a 30mm Slogging spanner to achieve enough torque. When the mast is assembled correctly only the top of the base plate will show above ground, as shown below. 
Maintenance :	No maintenance required

DECLARATION OF PERFORMANCE

No. 010.005-CPR-2013.09.04

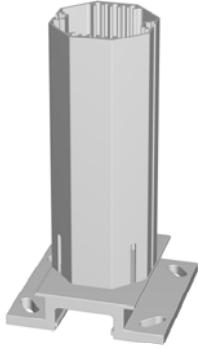

By JSK - Approved on behalf of the manufacturer by Lars Tvette, Vingrom 04.09.2013

<p>Order no. Mast :</p>  <p>Norsafe Mast NM190-60</p>	<table border="0"> <tr><td>22310050100</td><td>NM190-60 x 1,0 m mast complete w/base plate</td></tr> <tr><td>22310050200</td><td>NM190-60 x 2,0 m mast complete w/base plate</td></tr> <tr><td>22310050250</td><td>NM190-60 x 2,5 m mast complete w/base plate</td></tr> <tr><td>22310050300</td><td>NM190-60 x 3,0 m mast complete w/base plate</td></tr> <tr><td>22310050350</td><td>NM190-60 x 3,5 m mast complete w/base plate</td></tr> <tr><td>22310050400</td><td>NM190-60 x 4,0 m mast complete w/base plate</td></tr> <tr><td>22310050450</td><td>NM190-60 x 4,5 m mast complete w/base plate</td></tr> <tr><td>22310050500</td><td>NM190-60 x 5,0 m mast complete w/base plate</td></tr> <tr><td>22310050550</td><td>NM190-60 x 5,5 m mast complete w/base plate</td></tr> <tr><td>22310050600</td><td>NM190-60 x 6,0 m mast complete w/base plate</td></tr> <tr><td>22310050650</td><td>NM190-60 x 6,5 m mast complete w/base plate</td></tr> <tr><td>22310050700</td><td>NM190-60 x 7,0 m mast complete w/base plate</td></tr> <tr><td>22310050750</td><td>NM190-60 x 7,5 m mast complete w/base plate</td></tr> </table>	22310050100	NM190-60 x 1,0 m mast complete w/base plate	22310050200	NM190-60 x 2,0 m mast complete w/base plate	22310050250	NM190-60 x 2,5 m mast complete w/base plate	22310050300	NM190-60 x 3,0 m mast complete w/base plate	22310050350	NM190-60 x 3,5 m mast complete w/base plate	22310050400	NM190-60 x 4,0 m mast complete w/base plate	22310050450	NM190-60 x 4,5 m mast complete w/base plate	22310050500	NM190-60 x 5,0 m mast complete w/base plate	22310050550	NM190-60 x 5,5 m mast complete w/base plate	22310050600	NM190-60 x 6,0 m mast complete w/base plate	22310050650	NM190-60 x 6,5 m mast complete w/base plate	22310050700	NM190-60 x 7,0 m mast complete w/base plate	22310050750	NM190-60 x 7,5 m mast complete w/base plate
22310050100	NM190-60 x 1,0 m mast complete w/base plate																										
22310050200	NM190-60 x 2,0 m mast complete w/base plate																										
22310050250	NM190-60 x 2,5 m mast complete w/base plate																										
22310050300	NM190-60 x 3,0 m mast complete w/base plate																										
22310050350	NM190-60 x 3,5 m mast complete w/base plate																										
22310050400	NM190-60 x 4,0 m mast complete w/base plate																										
22310050450	NM190-60 x 4,5 m mast complete w/base plate																										
22310050500	NM190-60 x 5,0 m mast complete w/base plate																										
22310050550	NM190-60 x 5,5 m mast complete w/base plate																										
22310050600	NM190-60 x 6,0 m mast complete w/base plate																										
22310050650	NM190-60 x 6,5 m mast complete w/base plate																										
22310050700	NM190-60 x 7,0 m mast complete w/base plate																										
22310050750	NM190-60 x 7,5 m mast complete w/base plate																										
<p>Order no. Bolt set :</p> 	<p>22350000024 NM190-60 - NM290 Found. Bolt set M24</p> <p>M24 Bolt Set for foundation consists of: Threaded rod: 4 pcs. M24x150mm DIN 976B A4-80 Washer: 8 pcs. M24 25x60x8mm DIN 6340 316L (labeled A4) Nut: 8 pcs. M24 DIN934 A4-80 coated with Gleitmo 605 Spanner size tools: 36mm, impact wrench or torque wrench Torque: 754Nm - See separate documentation for torque.</p>																										
<p>CE marking and system of assessment and verification of constancy of performance:</p>	<p>The mast is CE marked; EN 12899:2007. Notified body nr. 1358, se attached certificate.</p> <p>System of assessment and verification of constancy of performance: System 1</p> <p>CE marking is approved and valid for: 2,5m – 7,5m mast lengths.</p> <p>All data and capacities are stated in the CE marking label. And there are in addition permanent marking for traceability on both mast and base plate</p>																										
<p>Referrals / Attachments:</p>	<p>Approval from Norwegian Road Authorities EC - Certificate of conformity Torque documentation</p>																										

CE
1358

Euroskilt AS
Paul A. Owrens veg 46
2607 Vingrom
+47 61 24 80 50
www.euroskilt.no

13

010.005-CPR-2013.09.04

NM190-60
Norsafe® Mast
EN12899:2007
M_b 60 kNm (M_u)
EI 1812,0 kN/m²
M_t 42 kNm (T_u)
GI_t 59,22 kN/m²
EN12767:2007
100, NE, 2

DECLARATION OF PERFORMANCE

No. 010.005-CPR-2013.09.04



By JSK - Approved on behalf of the manufacturer by Lars Tvette, Vingrom 04.09.2013

Assembly Instructions:

Yellow plastic with installation instructions that come mounted on Norsafe Mast M24 prefabricated foundation. The plastic is fitted with the plastic cap that seals the hole where bolts should be installed:

Front:

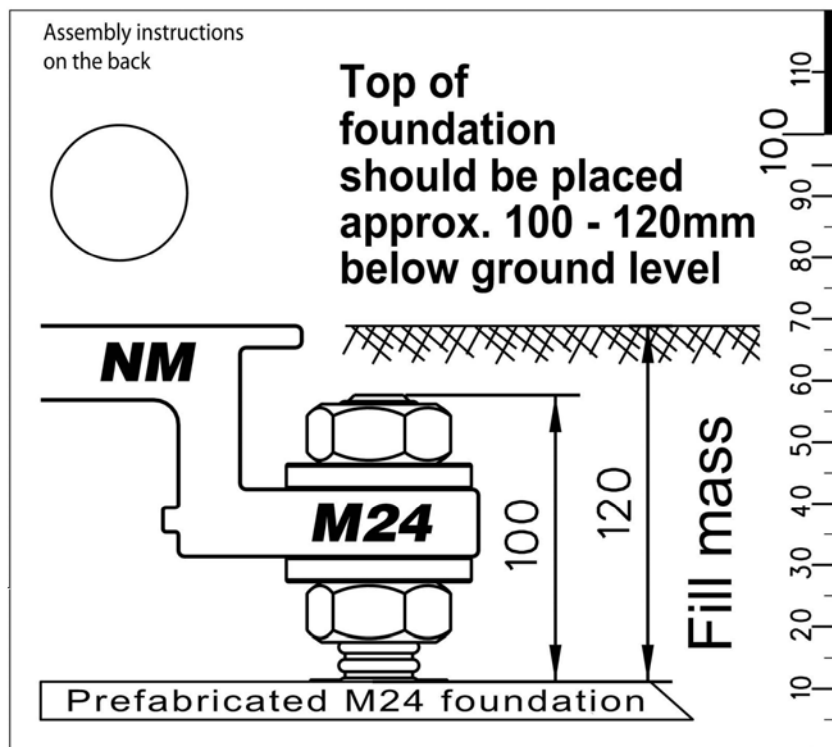

Back:

Assembly: **NM190-60 og NM290-100 (M24)**

1. Check with for example a plank laid over the hole and the ruler on the front that the foundation is mounted at the correct height so that the bolts will not stick up above the ground.
2. Bolts are screwed hard all the way down in to the foundation.
3. Remove the top four nuts and washers.
4. Levelling is made on the four lower nuts.
5. Place the mast with base plate and mount washers and nuts. The nuts are coated with Gleitmo 605 to prevent the stainless nuts to seize. Additional lubrication is not normally necessary. Do not use oil or grease. Install the nuts with **torque wrench (754Nm)** or **impact wrench (width 36mm)** to get enough torque; beat until the nut is no longer moving. Correctly installed = **only the top of the base plate should show above ground**

DECLARATION OF PERFORMANCE

No. 010.005-CPR-2013.09.04



By JSK - Approved on behalf of the manufacturer by Lars Tvette, Vingrom 04.09.2013

Drawing with dimensions for attachments on the top (M16) and on the side (M12):

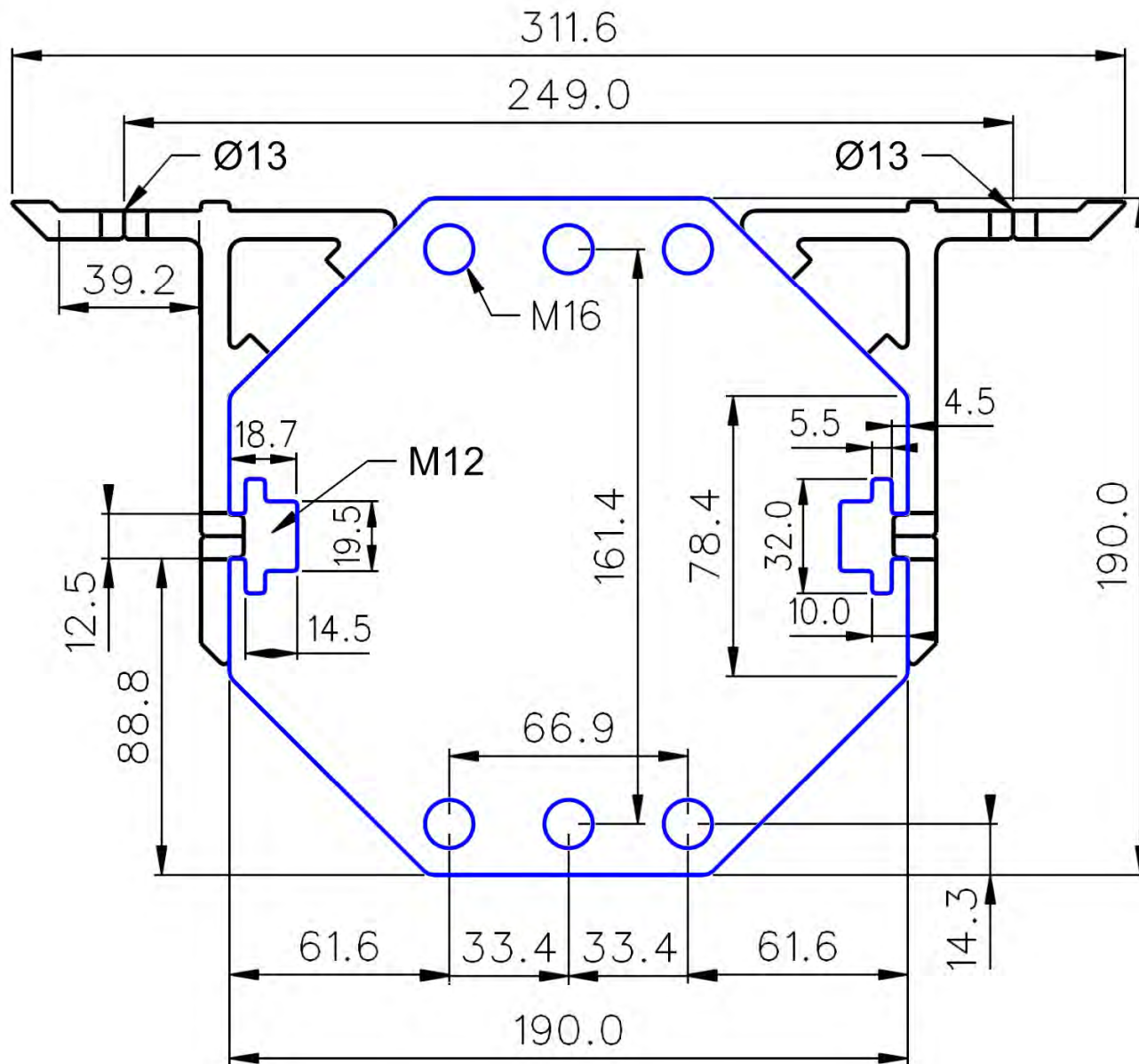



Výskumný ústav dopravný, a.s.

Forschungsinstitut für Verkehrswesen, AG
Transport Research Institute, J.S.Co.
Veľký Diel 3323, 010 08 ŽILINA



Reg. No. 033/P-001

Autorizovaná osoba SKTC-125, Autorizovaná osoba SK05, Notifikovaný orgán 1358
Authorized Body SKTC-125, Authorized Body SK05, Notified Body 1358

Certificate of constancy of performance

1358 – CPR – 0113

In compliance with Regulation 305/2011/EU of the European Parliament and of the Council of 9 March 2011 (the Construction Products Regulation or CPR), this certificate applies to the construction products

Norsafe[®] Mast

Types: NM 89-7,5; NM 120-15; NM 150-30; NM 190-45; NM 190-60; NM 290-100

The construction product is a support supplied for fixed vertical road traffic signs with the passive safety 100, NE, 3 and 100, NE, 2. The product is

produced by

EUROSKILT AS
Paul A Owrens Veg 46
2607 Vingrom
Norway

and produced in the manufacturing plant

EUROSKILT AS
Paul A Owrens Veg 46
2607 Vingrom
Norway

This certificate attests that all provisions concerning the assessment and verification of constancy of performance and the performance described in Annex ZA of the standard

EN 12899 - 1: 2007

under system 1 are applied and that

the product fulfils all the prescribed requirements set out above.

This certificate was first issued on 25.11.2013 and will remain valid as long as the test methods and/or factory production control requirements included in the harmonised standard, used to assess the performance of the declared characteristics, do not change, and the product, and the manufacturing conditions in the plant are not modified significantly.

Žilina 25.11.2013



Ing. Michal Kais
Head of NB 1358

052801



Statens vegvesen
Norwegian Public Roads
Administration

Euroskilt AS
Postboks 92 Forus
4064 STAVANGER
Norge

Executive unit:
Directorate of Public Roads

Contact person/direct line:
Matteo Pezzucchi - 22073246

Our reference:
2011/006855-025

Your reference:

Our date:
15.04.2011

Approval of "Norsafe" (Euroskilt AS) passive safe support

With reference to the Norwegian approval letter Journal nr 2004/050368-045 dated 12 March 2009 and the application from Euroskilt AS about approval of "Norsafe" passive safe support dated 23rd October 2008.

"Norsafe" supports are divided in two series:

1. Alluminium supports with octagonal profile (190 mm width) fixed with M16 bolts. Furthermore a product family is defined (NM190 series) including NM190-60 fixed with 6 breaking bolts and NM190-45 fixed with 4 breaking bolts.
2. Alluminium supports with width less than 190mm fixed with M12 bolts. This includes: full scale test support NM150-30 with octagonal profile fixed with 6 breaking bolts, NM120-15 and NM89-7, 5 fixed with 4 breaking bolts.

The application includes the following documents (tests carried out at the Nordic Test Center in Lista, the 3rd and 4th July 2008):

- Test report nr NTSr-08-006/A, on Euroskilt mast NM 290 (35 km/h)
- Test report nr NTSr-08-007/A, on Euroskilt mast NM 290 (100 km/h)
- Test report nr NTSr-08-008/A, on Euroskilt mast NM 150 (35 km/h)
- Test report nr NTSr-08-009/A, on Euroskilt mast NM 150 (100 km/h)
- Videos and pictures from the tests

Tests 08-006/A and 08-007/A are carried out with 6,5 m height mast and total weight of 268,1 kg. (Support + foot plate 120,6 kg / sign + brackets 137,5 kg)

Tests 08-008/A and 08-009/A are carried out with 5 m height mast and total weight of 140,3 kg. (Support + foot plate 52,9 kg / sign + brackets 87,4 kg)

Postal address
Statens vegvesen
Vegdirektoratet
Postboks 8142 Dep
N-0033 Oslo
NORWAY

Telephone: +47 02030
Telefax: +47 22 07 37 68
firmapost@vegvesen.no

Office address
Brynsengfare 6A
0667 OSLO

Address for invoices
Statens vegvesen
Regnskap
Båtsfjordveien 18
N-9815 VADSØ, NORWAY
Telephone: +47 78 94 15 50
Telefax: +47 78 95 33 52

Drawing (Rev. A):
NM 290-100 nr. EUV5113
NM190-60 nr. TOV0280
NM190-45 nr. TOV0279
NM150-30 nr. TOV0278
NM120-15 nr. TOV0279
NM 89-7,5

Foundations:

NM89-7,5 275 kg (Top: 0,361m, Bottom: 0,386m Height: 1,1m)
NM120-15 440 kg
NM150-30 540 kg
NM190-45 800 kg
NM190-60 950 kg
NM290-100 1730 kg

The tests are carried out in accordance with NS-EN 12767; test's results meet the requirements of the specified speed categories.

Norsafe passive safe supports receive the following approval:

- Norsafe passive safe support type NM290-100 with height 6,5 m and total weight 268,1 kg and NM190-60 NM190-45 in the same product family are approved in the 100,NE,2 performance class.
- Norsafe passive safe support type NM150-30 with height 5 m and total weight 140,3 kg and NM120-15, NM 89-7,5 in the same product family are approved in the 100,NE,3 performance class.

The acceptance is limited to use within Norwegian Public Roads Administration.

In case of any discrepancy between the English and the Norwegian approval letter, the Norwegian version should be act as the original.

Bridge Section
Regards

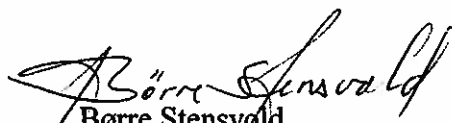
Børre Stensvold
Bridge Director

Otto Kleppe

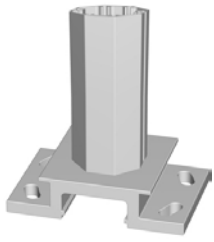

Norsafe[®] Mast



A Vision Zero Mast[®]

Norsafe Mast is a fourth generation signpost, designed to meet the Zero Vision goals.

The Norsafe Mast is only made of non corrosive materials / aluminium and stainless steel with an extensive lifespan. The mast is especially good to meet the demands in a slope due to a new light zero vision base plate instead of Slip-base. The mast is tested and approved EN 12767 and are CE marked EN12899.

Norsafe Mast has many fixing solutions. Norsafe Mast is low cost, maintenance free with a long life span and gives more signs for the money! Norsafe Mast is an aluminium deformation mast with break-off bolts. It does not need any Slip-base or equivalent solutions. That means that the light and soft mast first deforms and then does the bolts break off like the other third generation masts. In addition to keeping the characteristics of the older types of aluminium masts on the market, this mast has a number of new qualities.

This mast has gone further, an entire generation further, with the following improved qualities:

1. The mast is designed for assemblies in slopes with the new zero vision base plate. It has a special shape that assures that there are no remaining parts that can hit the undercarriage of the car after a collision in a slope as the case can be with older masts.
2. The mast can safely be hit from any direction; there are no foundation bolts sticking up to stop the mast in any directions.
3. Lower weight with light aluminium base plates – no heavy steel base plates. This makes it less demanding to assemble the mast by the road and in most cases can it be assembled by hand.
4. No danger for ice-expansion due to open water draining shapes for the bolt in the aluminium profile, due to this no water tight to-plate or cap is needed.
5. There are shapes in the mast profile for both standard bolts and T-bolts to make it easy to fasten; the customers can easily make their own customizations or fasteners for electrical boxes, cameras etc.
6. The mast can easily be cut in any length; you do not have to adjust the cutting length to any lattice.
7. Longer lifespan, only aluminium and stainless steel, no galvanized steel parts with short lifespan.
8. It has hidden foundation bolts so that the mast can be used in city environments on sidewalks etc. There is only a flat aluminium plate showing above ground. The foundation top is placed approximately 10cm under the ground.
9. Optimized foundations with increased ground surface area and increased stability, with a wider 20cm high bottom section that uses the surrounding soil efficiently to stabilize it further. At a lower cost than older foundations. It is also longer in the direction it must support the highest load. They are not deeper than 80cm so they can be assembled over shallow cables, beside mountains and over rock. All foundations can support the full capacity of the mast so no calculations or selections for the foundations are needed.
10. Norsafe Mast can be delivered with a break off plug, an IP68 flood safe electrical plug that releases horizontally in a collision. Both the plug and the cables are well protected inside the mast. The mast can also be delivered with pre-fitted connection plugs at desired positions, and then it is just plug & play !
11. Hi torsional strength (M_T). This is an important quality when calculating the torsion you get when the wind is not blowing perpendicularly to the sign and the load point from the wind moves 1/4 of the sign width. Where you need to use to lattice mast you can often use a single Norsafe Mast due to the high torsional strength.
The calculation of askew wind load resulting in torsion is often called the W/4 rule. It is based on physical facts and is mandatory according to both national standards and Eurocode (EN 1991-1-4 p.7.4.3)
12. Stainless steel nuts (A4) for fixings and foundations are coated with Gleitmo 605 to not seize, additional lubrication is not necessary, making assembly of mast, foundations and fixings safer and easier.
13. The mast is climb protected.

